

TUFLOK®: NYLON® LOCKING

TUFLOK®: NYLON® LOCKING

Tuflok® is the world's most widely used nylon-locking product. It is also known as «Nylon® Blue Patch» in Asia and the United States.

This mechanical locking process can be found on a very large range of applications, from standard screws to special aerospace fasteners.

Tuflok® is particularly recommended for applications where adjustment during assembly or final use is necessary: adjustment screws, temporary positioning, etc. and in general all applications subjected to vibrations.

Tuflok® is a nylon powder sprayed on a warmed threaded part. When it is screwed down, the nylon is compressed.

The radial tension created by the elastic deformation of the product causes position retention through increased friction. The parts that are retained can be repositioned as the nylon deformation is partially reversible so that part can be screwed down and unscrewed several times. The retaining function is immediately active once screwed down.

TUFLOK® 180

The coating of Tuflok® 180 is applied on approx. 180° of the screw circumference. It offers excellent resistance to impacts and vibration. It is also reusable a number of times. Tuflok® is even effective on assemblies under tension. It is particularly recommended for adjustment screws.

Tuflok®360

The coating of Tuflok® 360 is applied on the entire circumference of the part. It is recommended for applications that need thread locking and/or sealing liquids or gas. It is also reusable a number of times.

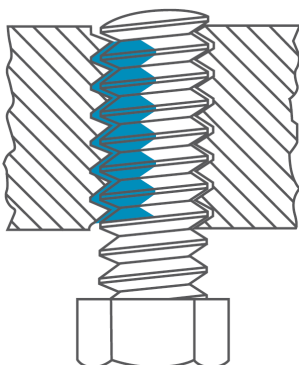

Tuflok® patches are well known for their cost benefits. They allow the same screw to be reused a number of times. As a result, maintenance and disassembly operations are simplified and cheaper.





ADVANTAGES

- Reusable several times
- Good resistance to impacts and vibration
- Adjustable torque to match the application
- Adjustable position and width of the patch
- Replaces retaining systems using a nut, self-locking nut, lock washer, cotter pin, etc.
- Retaining with or without tension in the assembly
- No polymerisation: immediate locking and sealing
- Good resistance to chemicals: alcohol, petroleum, diesel, oils, kerosene

TECHNICAL DATA

Temperature of use	-56°C à +120°C
Storage of coated screws	Unlimited
Coefficient of friction	0.3 / 0.4
Deposit over 180°	Low mechanical locking
Deposit over 360°	Low mechanical locking + sealing
Reusable (disassembly / complete reassembly)	5 times

COATING

- The adjustment should be 6g/6H, even after treatment. Lower tolerances may cause the pre-coating product to peel off.
- An entry chamfer of at least 90° is recommended to avoid phenomena like product rise and peeling.
- The surfaces in contact must be compatible (pay attention to heat expansion).
- We remind you that lubricants have a negative influence on product withstand.

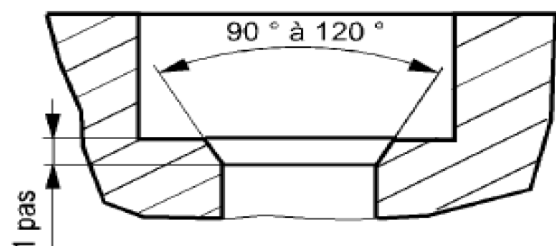
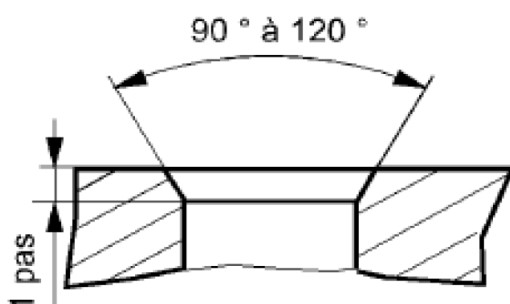



STANDARD POSITION AND LENGTH

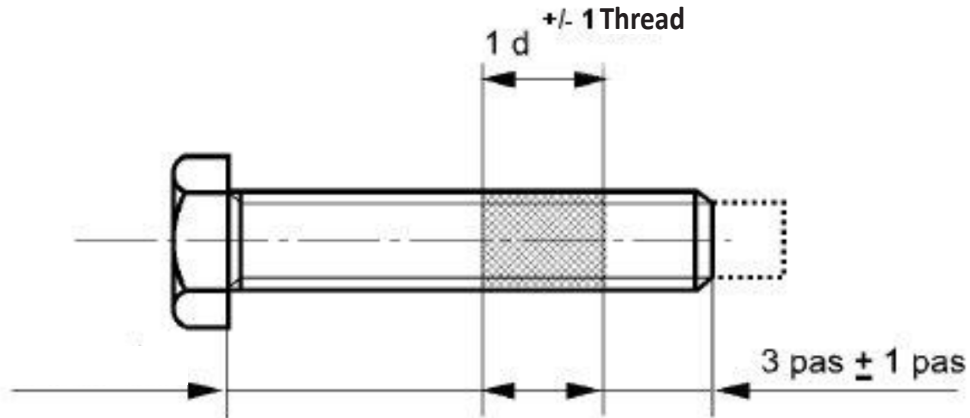

Note: When the thread is less than 1.25 in length and the diameter less than 8mm, the pre-coating length may be 0.6 to 0.8 times the diameter.

TIGHTENING TORQUES

Capacity: M2 – M18

\emptyset ISO 6g	First screwing max. Nm	First unscrewing min. Nm	Fifth unscrewing min. Nm
M2	0,2	0,04	0,02
M3	0,45	0,1	0,05
M3,5	0,7	0,2	0,1
M4	0,9	0,28	0,17
M5	1,6	0,4	0,23
M6	3	0,8	0,4
M8	6	1,5	0,8
M10	9,5	2,3	1,2
M12	13	3,4	1,7
M14	19	4,5	2,3
M16	28	7	3,5
M18	36	9	4



RECOMMENDATIONS

- The degree of filling with Tuflok® varies depending on the application. The torque values are used to adjust the machine.
- To guarantee improved Tuflok® adherence, avoid any prior part contamination (oil-film forming agent, etc.).
- To guarantee that the product will bond to the part, stainless steels must be passivated.
- Tuflok® powder is sprayed onto a preheated part and very precisely aimed. This way the patch will meet its stated specifications.
- Film forming agents should be applied after the pre-coating.

ASSEMBLY

- The assembly speed must be checked and reduced during the final tightening. A speed of 30 rpm is recommended by the manufacturer.
- Assembly is immediate: there is no polymerisation stage.
- The Tuflok® patch can be reused (a number of assemblies / reassemblies) but the torque values will be reduced.



DELIVERY – STORAGE

- We recommend allowing the product to cure for at least 24 hours after depositing the products and prior to shipping.
- There is no limit to how long coated but unassembled products may be stored.
- Once the assembly is performed, there is no limit to its service life.

QUALITY

Our facilities are all ISO 9001 certified and our quality systems meet the specialist requirements of the automotive and aeronautics industries.



APPROVALS

Tuflok® has been approved under a number of standards:

- | | |
|---------------------|----------------|
| ■ Renault 39-02-010 | ■ BS 7715:1994 |
| ■ P.S.A B141235 | ■ GM 6189p |
| ■ DIN 267-28 | ■ WA 970 |
| ■ IFI124 & 524 | ■ JFS 02.01.04 |

Non-exhaustive list